

# CD-14 HAND HELD CORE DRILL

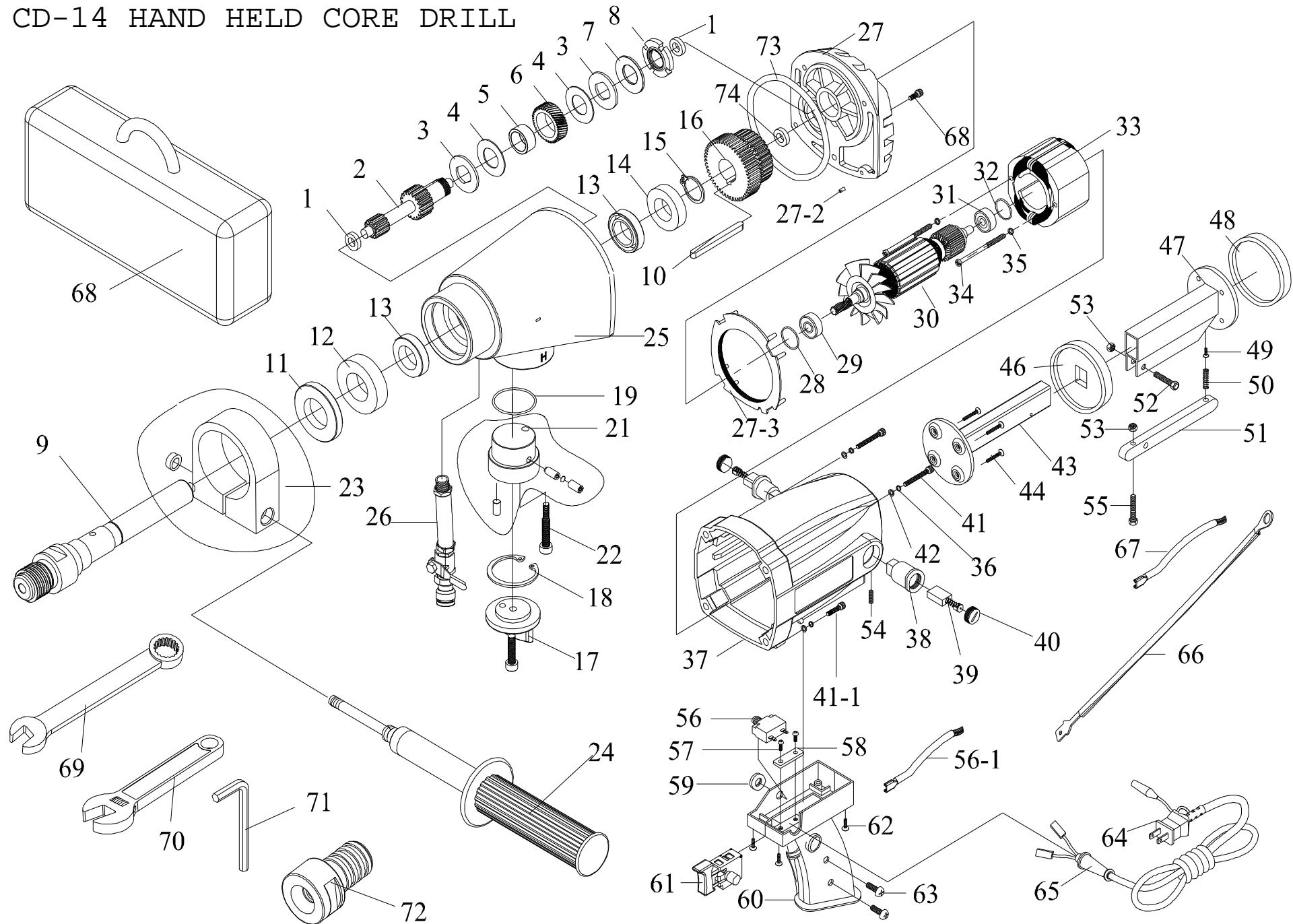

# CD-14 HAND HELD CORE DRILL

Item No.	Part No.	Qty.	Description	Item No.	Part No.	Qty.	Description
1	2705550	3	Bearing 608ZZ/CM	38	2705587	2	Brush Tube 7*11
2	2705551	1	Shaft, Secondary	39	2705589	1	Carbon Brush (2)
3	2705552	2	Plate	40	2705590	2	Brush Cover
4	2705553	2	Friction Plate	41	2705591	4	Screw M5 X 0.8 X 40
5	2705554	1	Copper Collar	42	2705592	4	Spring Washer M5
6	2705555	1	Gear, Second	43	2705593	1	Telescoping Tube
7	2705556	1	Disk Spring	44	2705594	4	Screw 5/32" x .625
8	2705557	1	U-Nut	45	2705595	4	Nut M5 (NO LONGER REQ.)
9	2705558	1	Spindle 5/8"-11	46	2705596	1	Holder
10	2705559	1	Woodruff Key	47	2705597	1	Telescoping Tube
11	2705560	1	Seal, 25x50x8	48	2705598	1	Holder
12	2705561	1	Ball Bearing 6005LLU	49	2705599	1	Screw 1/8"
13	2705562	2	Seal, 22x35x8	50	2705600	1	Spring
14	2705563	1	Bearing 6904LLU	51	2705601	1	Shifter
15	2705564	1	S-ring S20	52	2705602	1	Screw M6 X 35
16	2705565	1	Gear, First	53	2705603	2	Nut M6
17	2705566	1	Speed shift knob	54	2705588	2	Screw M5 X 0.8 X 10
18	2705567	1	R-ring R32	55	2705604	1	Screw M6 X 25
19	2705568	1	O-ring	56	2705605	1	Circuit Breaker
20	N/A		See Figure #21 (2705570)	57	2705606	2	Screw 5/32" X .500
21	2705570	1	Speed Shift Base	58	2705607	1	Cable Fix Plate
22	2705571	1	Screw, M5X0.8X45	59	2705608	1	Washer
23	2705572	1	Handle Collar	60	2705609	1	Switch Box
24	2705573	1	Handle	61	2705610	1	Power Switch
25	2705574	1	Gear Case	62	2705611	4	Screw 5/32" X 1.500
26	2705575	1	Hose Set	63	2705612	2	Screw 5/32" X .750
26.2	2705622	1	Plastic Hose	64	2705613	1	Electric Cable
26.3	2705623	1	Fitting, Brass Barb 3/4" X 3/8"	65	2705614	1	Female Quick Connect
27	2705576	1	Diaphragm	66	2705615	1	Ground Cable
27.2	2705855	1	Pin	67	2705616	1	Cable
27.3	2705856	1	Baffle	68	2705617	1	Carrying Case
28	2705577	1	O-Ring 224	69	2705618	1	27mm Wrench
29	2705578	1	Bearing, 609LLU/C3	70	2705619	1	Adjustable Wrench
30	2705579	1	Armature	71	2705620	1	5 mm Allen Wrench
31	2705580	1	Bearing, 608ZZ/C3	72	2705621	1	Adaptor 5/8"-11 to 1 1/4"-7
32	2705581	1	Filling Ring 608	N/A	2705624	1	Tool Set (includes #69-72)
33	2705582	1	Field	73	2705857	1	O-ring (80X2.0MM)
34	2705583	2	Screw 3/16 x 2.500	74	2705858	1	Bearing (608ZZ)
35	2705584	2	Spring Washer M5				
36	2705585	2	Nut M5 (NO LONGER REQ.)				
37	2705586	1	Motor House				